

# L-series

500PS [368kW] acc. to ISO 8665

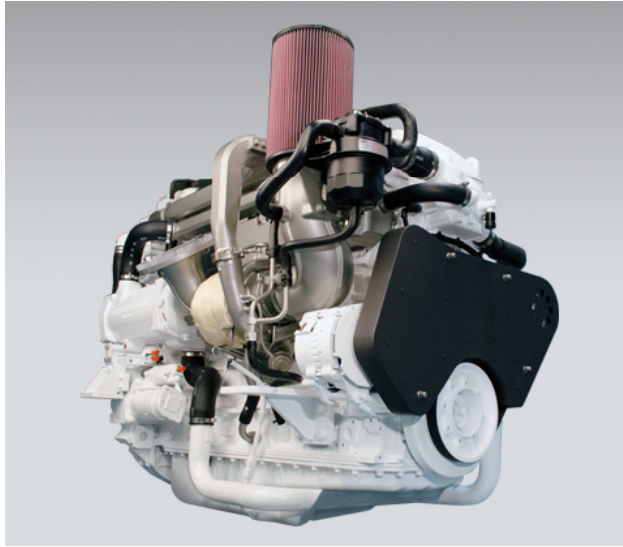

## Stable Performance at High Load

The Electronic Unit Injection system delivers 500PS and 232kg·m of torque from the 12.7 liter in-line 6 cylinder engine.

The robustly-designed unit was specifically conceived as a heavy duty engine with the ability to serve the professional and commercial markets. It has stable performance at high load and responds well to sudden load changes.

Excellent power and torque in a wide rpm range proves Hyundai SeasAll's diesel development capabilities are world-class and beats the performance of competition's comparable models. Economy is assured by the state-of-the-art fuel management system featuring electronic unit injectors (EUI). The electronic engine control system makes it lighter, quieter and more fuel efficient in a surprisingly compact package.

The L500 provides excellent value-both at the time of purchase and during operation. It is economical and clean running-both attributes which appeal to the professional mariner.

## Technical Descriptions

### Engine

- 6 cylinder in-line, 24-valve OHC
- Cast iron cylinder block and cylinder head
- Gallery oil-cooled long lasting mono steel pistons
- Integrated water jacket
- Single serpentine belt system
- Drive belt auto tensioner

### Engine Mounting

- Adjustable engine mounts ( Optional )

### Lubrication System

- Gear-driven engine oil pump
- Closed system with forced feeding
- Integrated oil-cooler in cylinder block
- Easily exchangeable oil filter cartridge
- Eco type oil filter
- Washable auxiliary cyclone oil filter
- Electric oil extraction pump

### Fuel System

- Electronic Unit Injector (EUI)
- Gear-driven fuel pump
- Electronically controlled injection timing
- Fine fuel filter and water separator<sup>L</sup>
- High pressure six-hole injector nozzles

### Electrical System

- 24 volt - 80A alternator
- Auxiliary engine stop button
- Air heating system for a trouble-free cold start
- NMEA2000 Converter (Optional)

### Cooling System

- Gear-driven seawater pump
- Seawater-cooled intercooler, heat exchanger
- Auxiliary connector for cabin heating
- Corrosion resistant material for seawater circuit
- Easily accessible rear mounted sea-water pump

### Instrument Box Assembly (Standard)



- Engine self-protection and diagnosis
- Displays CAN information
- Displays engine diagnostic error codes
- Audible alarm and control lamps
- Idle & PTO rpm adjustable switch

### Air Inlet system

- Reusable air filter
- Intake Extension Kit(Optional)

### Exhaust System

- Coolant cooled exhaust manifold
- Cast iron exhaust pipe
- WGT (Waste Gate Turbocharger)

### Emissions

- IMO NOx Compliant

### Type Approval

- RINA Classification Society

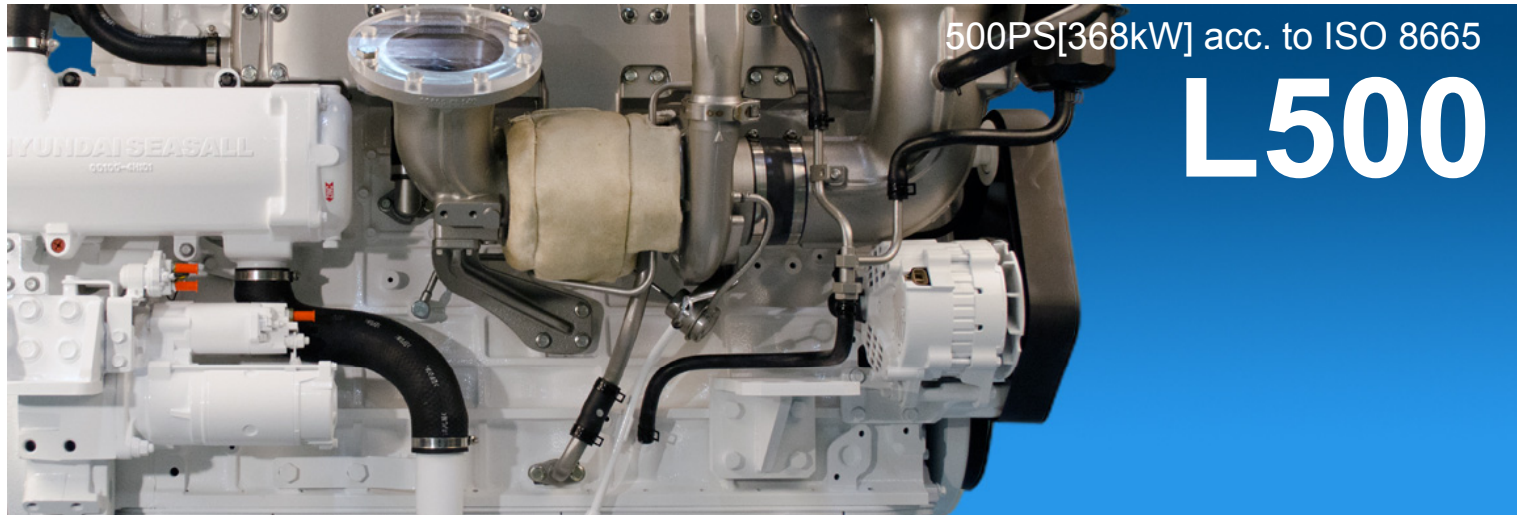

500PS[368kW] acc. to ISO 8665

# L500

## Specifications

Engine type	L500
Propulsion System	Shaftdrive
Engine Duty Rating	Heavy Duty (S1)
Configuration	4-Stroke, 24-Valve OHC, VGT with Intercooler, Fresh Water Cooling
Output [PS(kW)]	500 (368)
rpm @ full load	1,800
Cylinders	In-line 6
Displacement [cc]	12,736
Bore X Stroke [mm]	130 X 160
Compression Ratio	16 : 1
Max. Torque @ rpm	232kg·m @1,200rpm
Injection System	Electronic Unit Injectors (EUI)
Alternator [A]	24V-80A
Engine Diagnostics	YES
Max. Fuel Consumption [l/h]	88
Dry Weight [kg]	1,310
Flywheel	SAE 14
Flywheel Housing	SAE 1

## Performance Curves

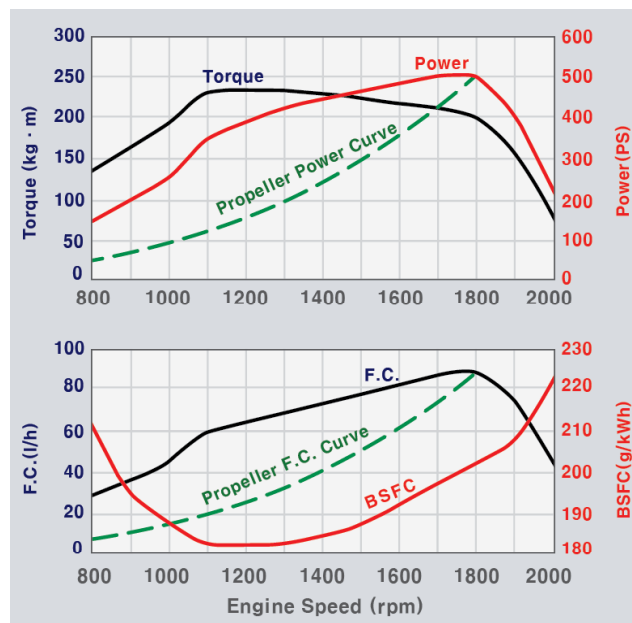

## L500

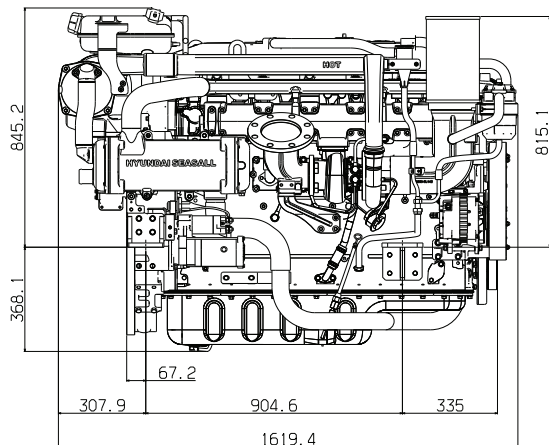

Side View

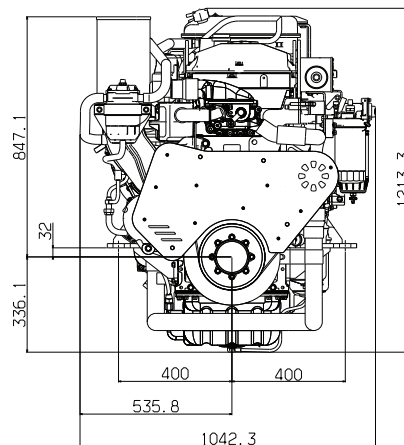

Front View

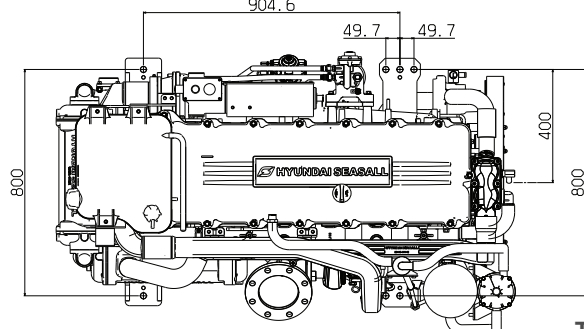

Top View



※ Text and data contained herein are subject to change without prior notice. Product availability differs by region. Contact your dealer for the most recent information.